



CONSTIX™ Swab, SV-3

Sealed polyester swabs for surface cleaning validation

Description

The SV-3 is a sealed polyester swab that's been specifically designed for validation of surface cleaning protocols. The head is constructed of a double layer knit polyester fabric that's been cleaned using a proprietary process to minimize background TOC contribution. The polyester head is constructed without adhesives or binders, which makes the swab compatible with most common solvents, such as alcohols and ketones.

The large paddle of SV-3 provides broader surface coverage for contamination retrieval in critical applications. The head is thermally bonded to a notched polypropylene handle to minimize handling and improve insertion in vials. The swab can be sterilized by most common methods and the small put up ensures accurate testing with little waste. Each pack of SV-3 contains five swabs packaged inside a cleanroom grade zipper bag.

Technical Data

Certified Low TOC	<50 µg/L (ppb)
Swab head material	Dual Layer 100% Knit Polyester
Swab handle material	100% Virgin Polypropylene with Notches
Construction	Thermally Sealed
Packaging	Five Swabs per Cleanroom Grade Zipper Bag

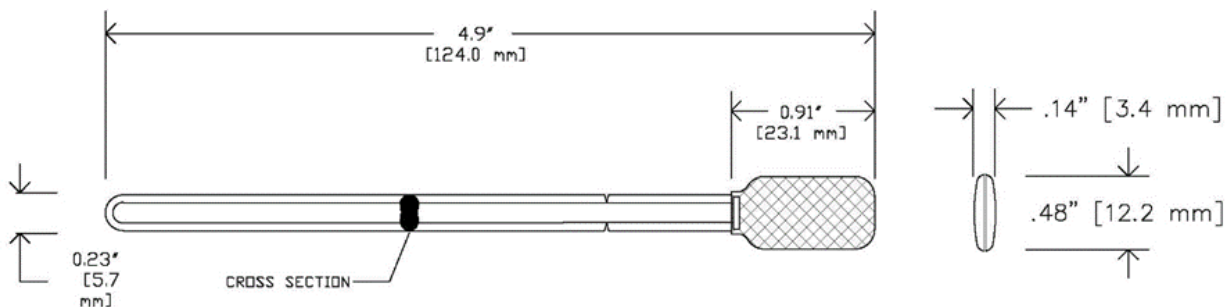

Notes:

- 1) Data shown are typical values and should not be used as product specifications.
- 2) Valid product comparisons may only be obtained through side-by-side testing in the same test facility, under similar conditions.
- 3) Current and/or comparison data may be available. Please contact a Contec sales representative for details.

Revision date: 03/01/18



Copyright © 2018 Contec, Inc. All rights reserved.

North America
 P.O. Box 530
 Spartanburg, SC 29304 USA
 Phone: +1-864-503-8333
 www.contecinc.com

Europe
 ZI du Prat – RP 3707
 56037 VANNES Cedex
 FRANCE
 +33 297 437 698

China
 No.17 Longyun Road
 Suzhou 215024
 CHINA
 + 86-512-6274 4050